

SPLIT TYPE
AIR CONDITIONER
DUCT TYPE (50Hz)

SERVICE MANUAL

Indoor unit	Outdoor unit
ARYC45LCTU	AOYD45LATT
ARYC54LCTU	AOYD54LATT



CONTENTS

SPECIFICATIONS.....	1
DIMENSIONS.....	2
REFRIGERANT SYSTEM DIAGRAM.....	4
CIRCUIT DIAGRAM.....	5
INDOOR PCB CIRCUIT DIAGRAM.....	6
OUTDOOR PCB CIRCUIT DIAGRAM....	7
ERROR DETECTION.....	14
PARTS (INDOOR UNIT).....	18
PARTS (OUTDOOR UNIT).....	20
ACCESSORIES.....	24

SPECIFICATIONS

ELECTRICAL DATA

TYPE		Cooling & Heating	
INDOOR UNIT		ARYC45LCTU	ARYC54LCTU
OUTDOOR UNIT		AOYD45LATT	AOYD54LATT
COOLING CAPACITY		12.5 kW	14.0 kW
HEATING CAPACITY		14.0 kW	16.0 kW
POWER SOURCE		400 V 50 Hz 3 ϕ 4 W	
RUNNING CURRENT	Cooling	6.1 A	6.9 A
	Heating	5.5 A	6.5 A
INPUT WATTS	Cooling	4.06 kW	4.65 kW
	Heating	3.67 kW	4.37 kW
E.E.R.	Cooling	3.08 kW/kW	3.01 kW/kW
	Heating	3.81 kW/kW	3.66 kW/kW
STARTING CURRENT		10.0 A	10.0 A
MOISTURE REMOVAL		1.5 L/hr	2.5 L/hr
AIRCIRCULATION INDOOR		3,350 m ³ /h	3,350 m ³ /h
AIRCIRCULATION OUTDOOR	Cooling	6,900 m ³ /h	6,900 m ³ /h
	Heating	6,200 m ³ /h	6,900 m ³ /h
MAXIMUM CURRENT		11.0 A	12.0 A

FAN MOTOR

INDOOR UNIT	Discrimination	MFA-60TTFS	
	High speed	1,300 r.p.m.	1,300 r.p.m.
	Middle speed	1,150 r.p.m.	1,150 r.p.m.
	Low speed	1,000 r.p.m.	1,000r.p.m.
OUTDOOR UNIT (cool / heat)	Discrimination	MFE-54TV	
	Upper fan	900 / 780 r.p.m.	900 / 850 r.p.m.
	Lower fan	800 / 750 r.p.m.	800 / 850 r.p.m.

NOISE LEVEL

INDOOR UNIT	High speed	47 dB	47 dB
	Middle speed	43 dB	43 dB
	Low speed	40 dB	40 dB
OUTDOOR UNIT	Cooling	54 dB	55 dB
	Heating	54 dB	56 dB

Note : Static pressure : 100pa

Duct length : Inlet 1m, Outlet 2m

DIMENSIONS

INDOOR UNIT	H x W x D	400 x 1,050 x 500 mm
OUTDOOR UNIT	H x W x D	1,290 x 900 x 330 mm

WEIGHT

INDOOR UNIT	Gross / Net	51 kg / 46 kg
OUTDOOR UNIT	Gross / Net	117 kg / 107 kg

COMPRESSOR AND REFRIGERANT

TYPE	Hermetic type, Inverter, 4 poles, 3 phase, DC motor, Twin Rotary		
DISCRIMINATION	808 677 80		
WEIGHT (with oil)	25.6 kg		
REFRIGERANT TYPE	R410A		
PRECHARGED REFRIGERANT	3,450 g		
MAX PIPE LENGTH	75 m		
MAX PIPE HEIGHT	30 m		
FULL CHARGE	Pipe length	30 m	3,450 g
		45 m	4,200 g
		60 m	4,950 g
		75 m	5,700 g
ADDITIONAL CHARGE	50 g/m		

OUTLINE AND DIMENSIONS

INDOOR UNIT

(Unit : mm)

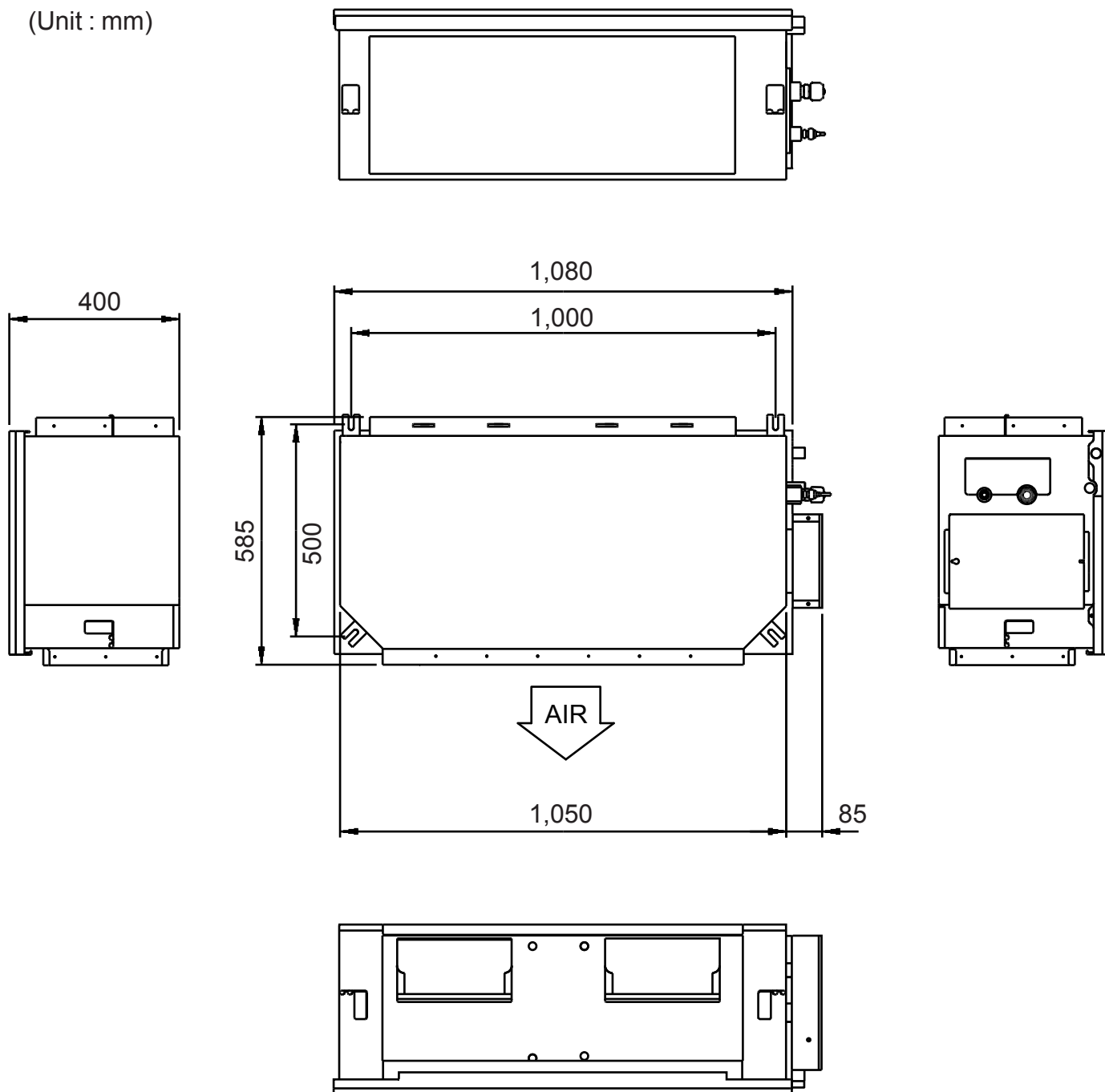

OUTDOOR UNIT
(unit : mm)

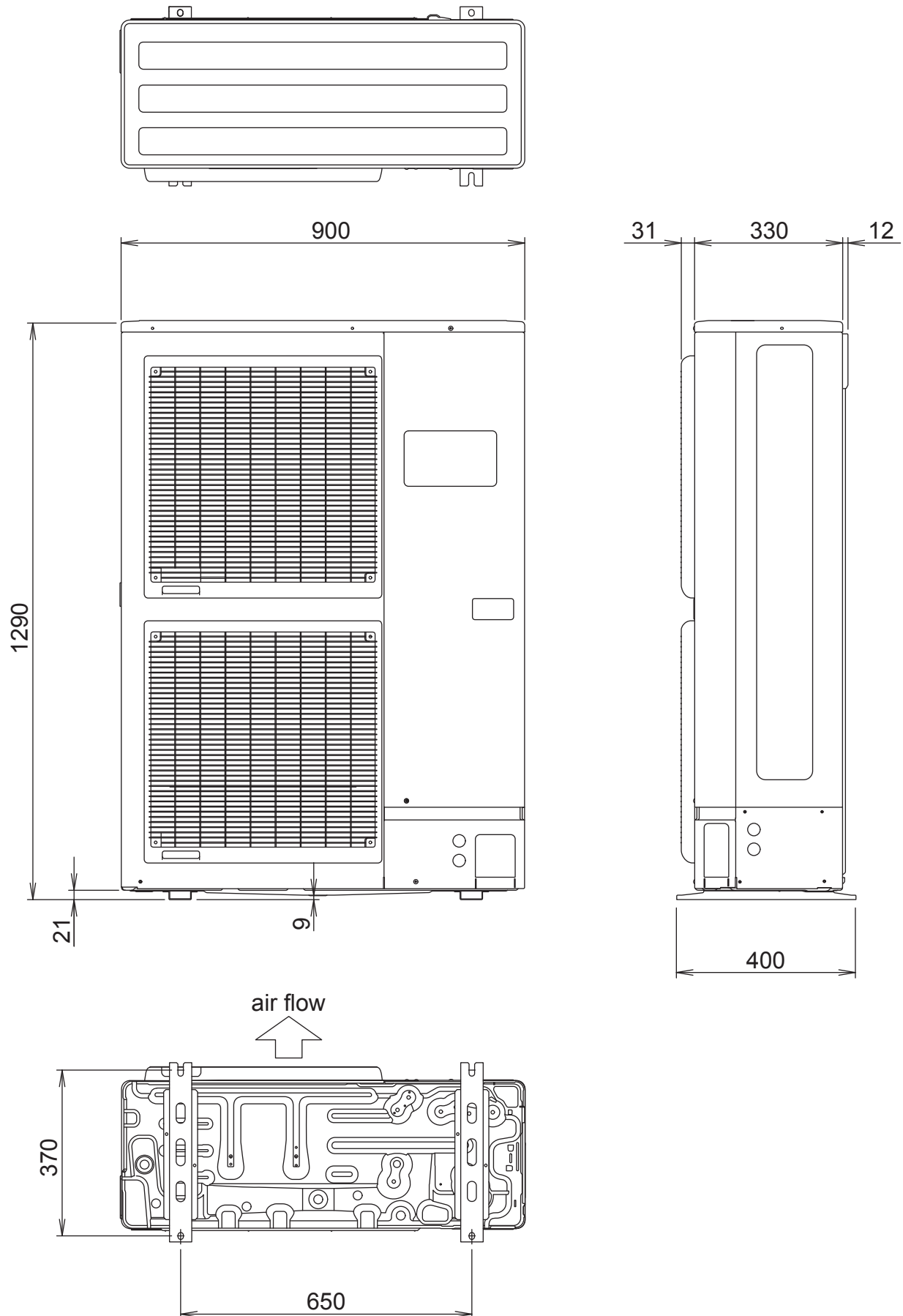

REFRIGERANT SYSTEM DIAGRAM

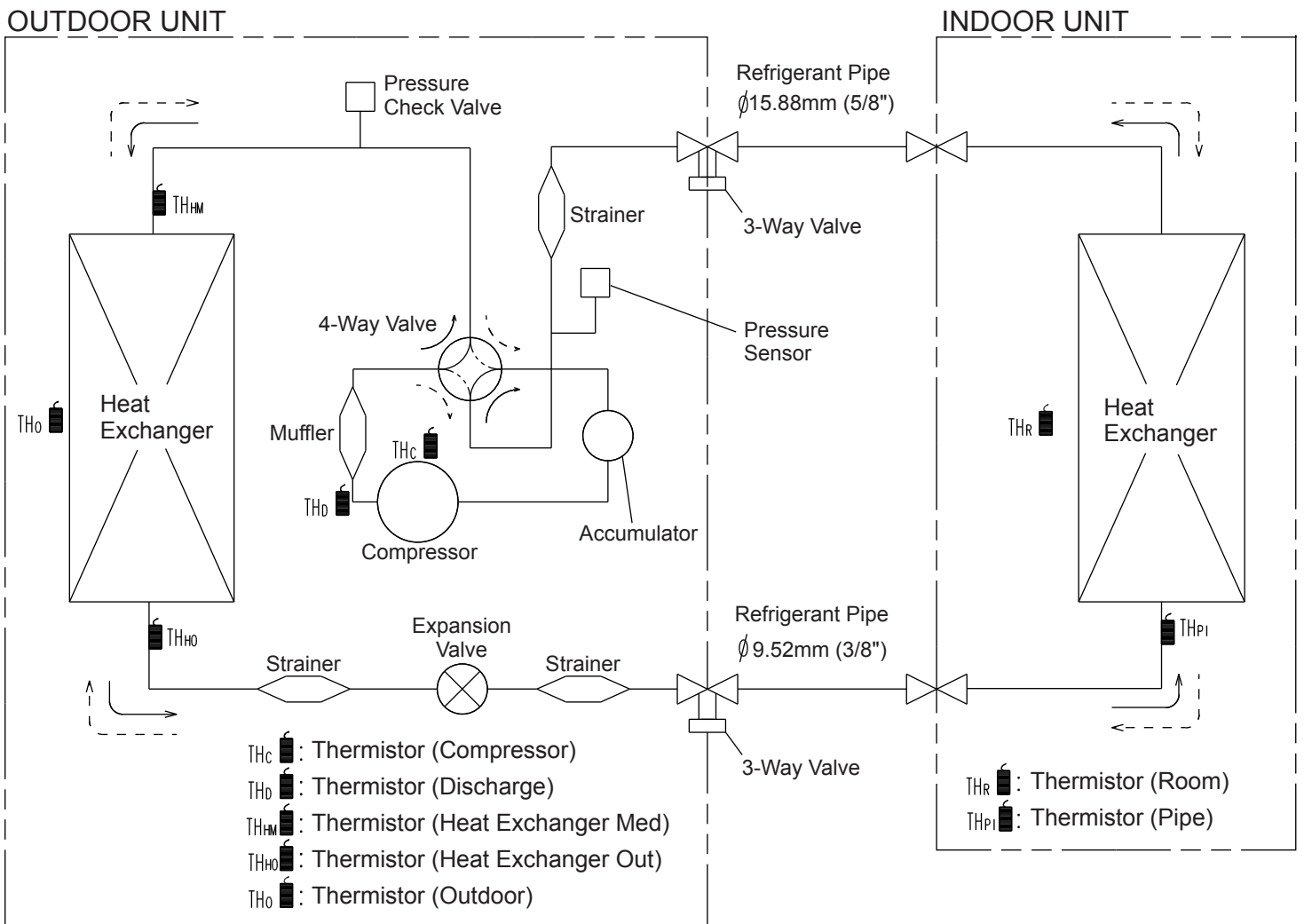

Refrigerant direction

→ : Cool

- - -> : Heat

CIRCUIT DIAGRAM

INDOOR UNIT

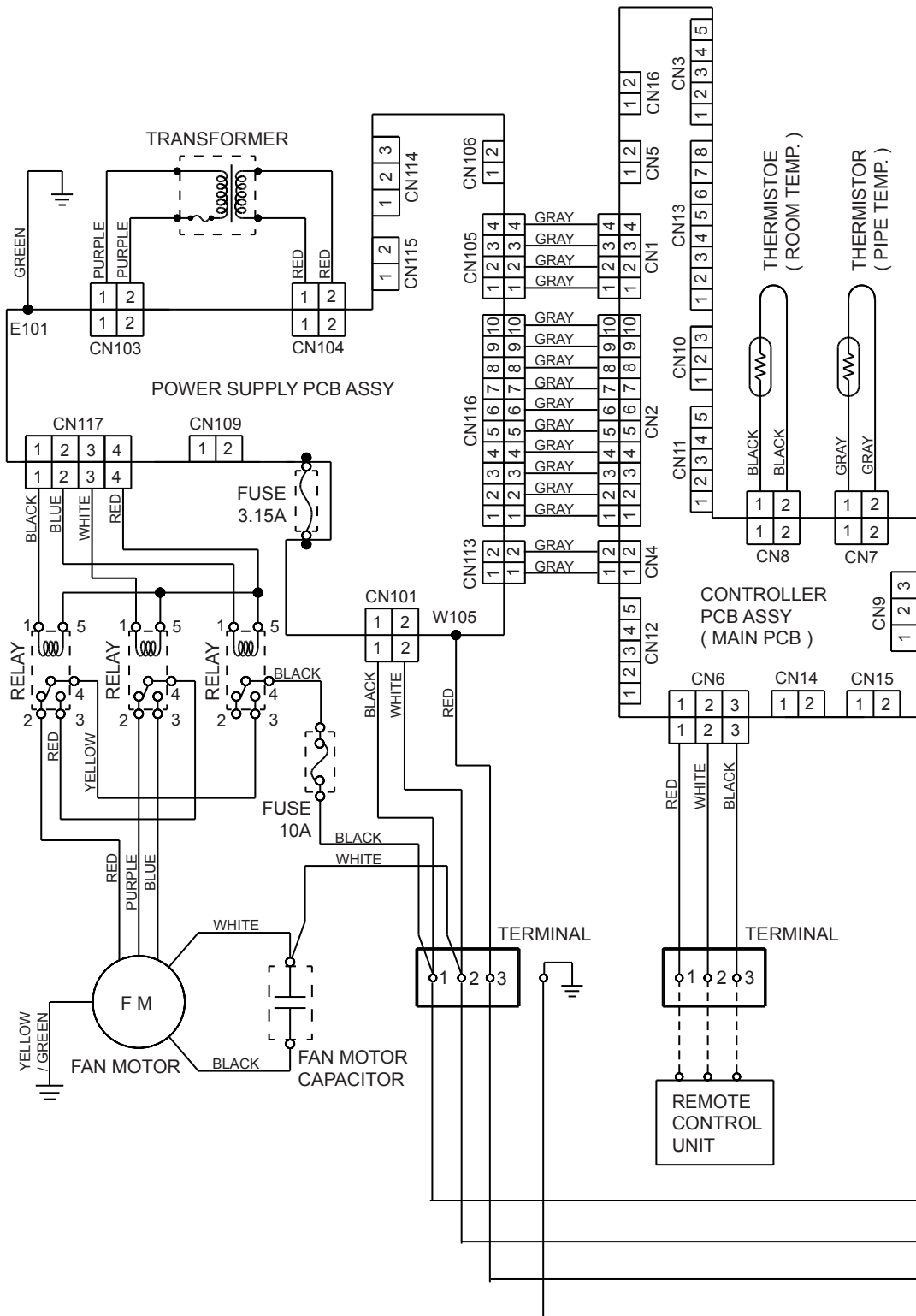

OUTDOOR UNIT

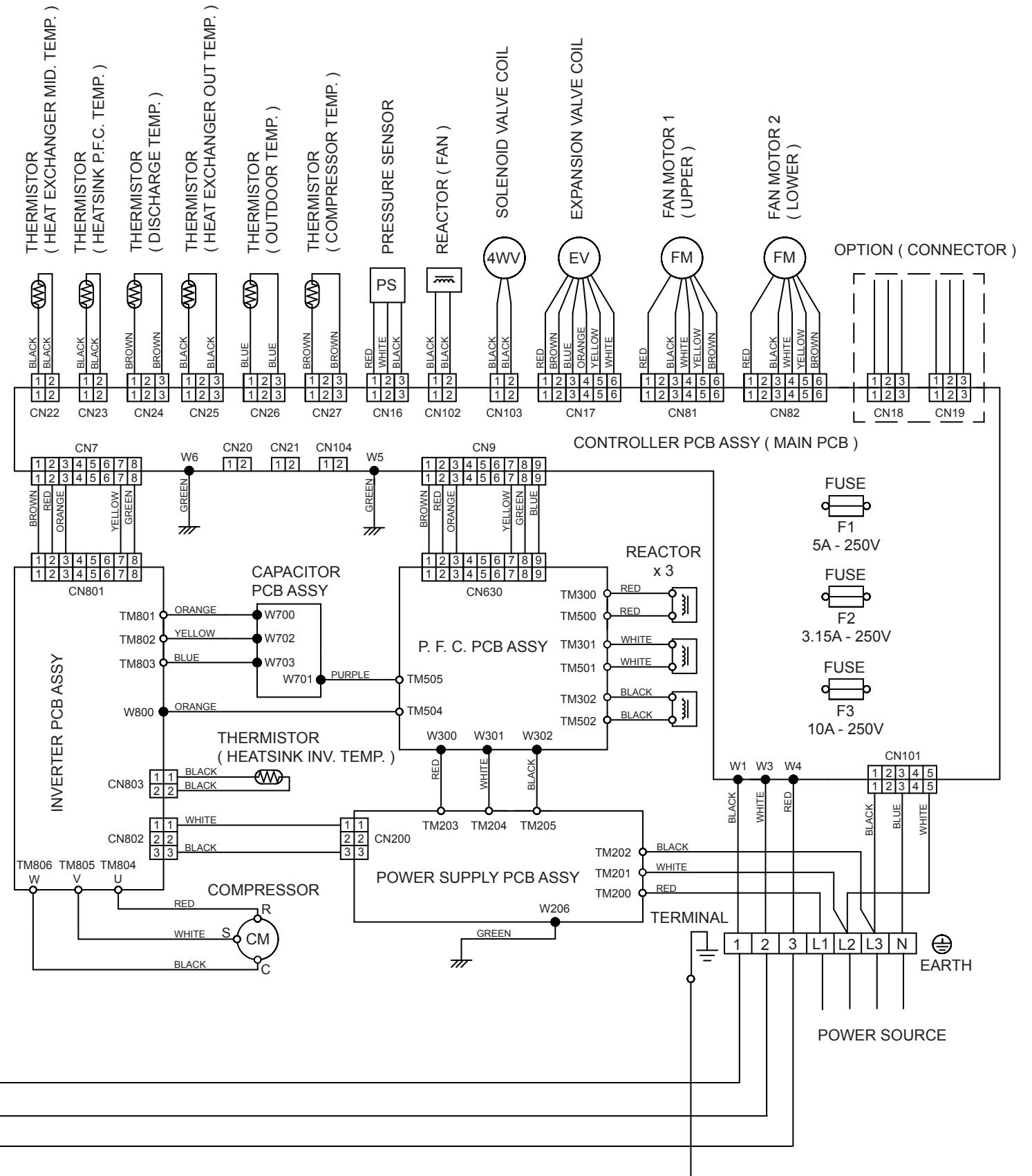

INDOOR PCB CIRCUIT DIAGRAM

CONTROLLER PCB ASSEMBLY
 ARYC45LCTU : K03BZ-0802HSE-C1
 ARYC54LCTU : K03BZ-0801HSE-C1

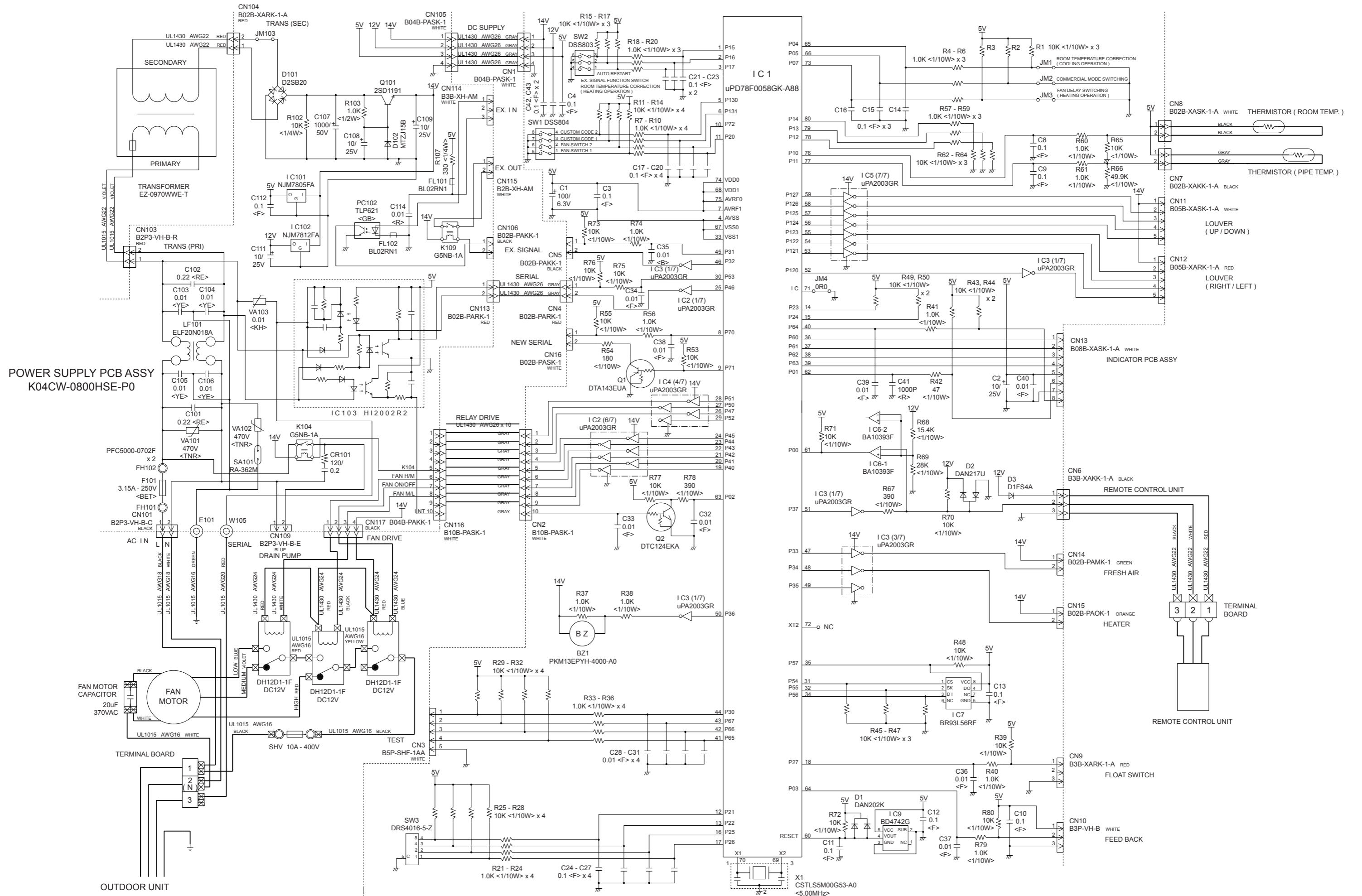

OUTDOOR PCB CIRCUIT DIAGRAM

INVERTER ASSEMBLY
 AOYD45LATT : EZ-0071HUE
 AOYD54LATT : EZ-0072HUE

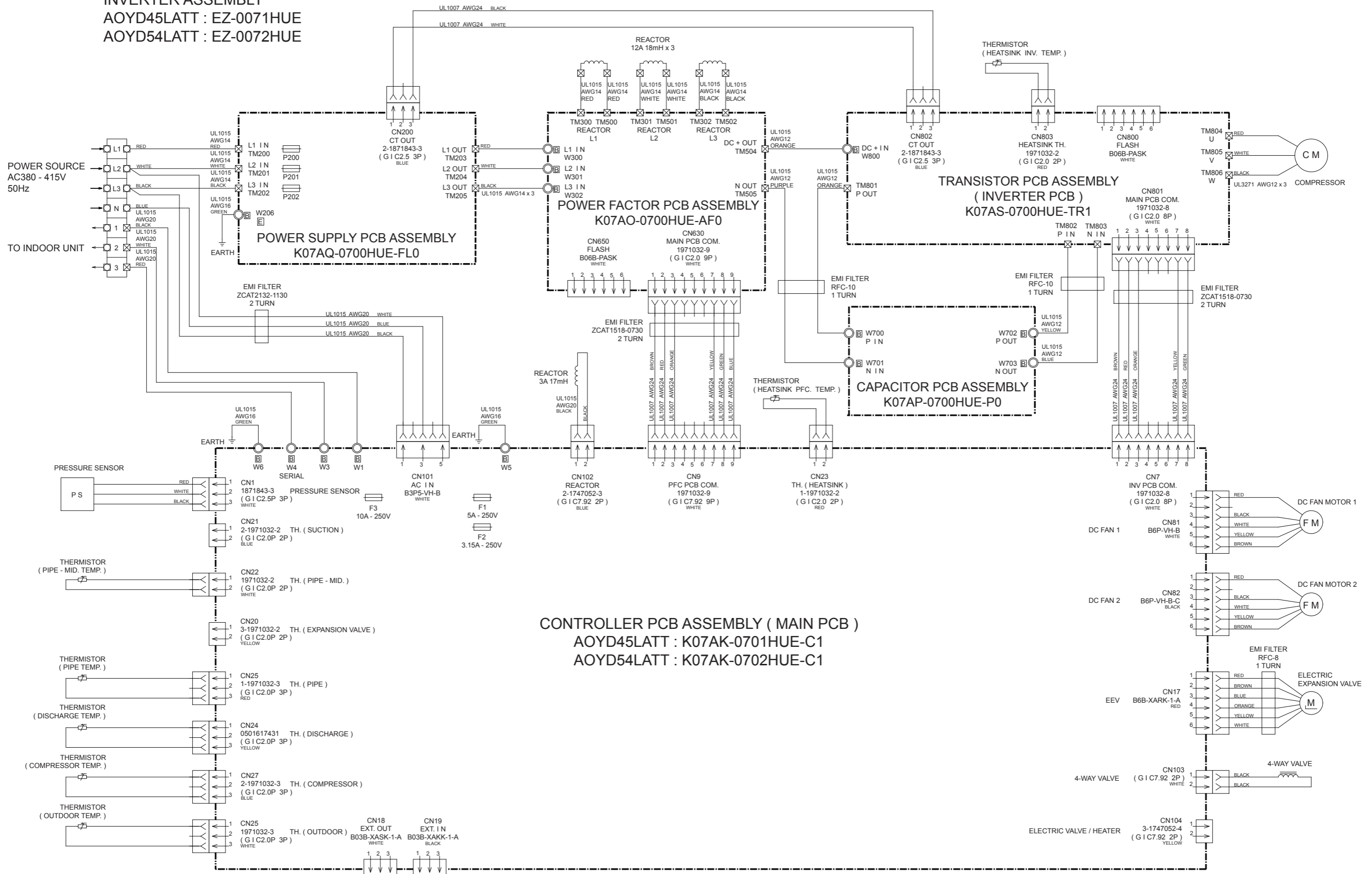

OUTDOOR UNIT
 CONTROLLER PCB ASSEMBLY
 AOYD45LATT : K07AK-0701HUE-C1
 AOYD54LATT : K07AK-0702HUE-C1

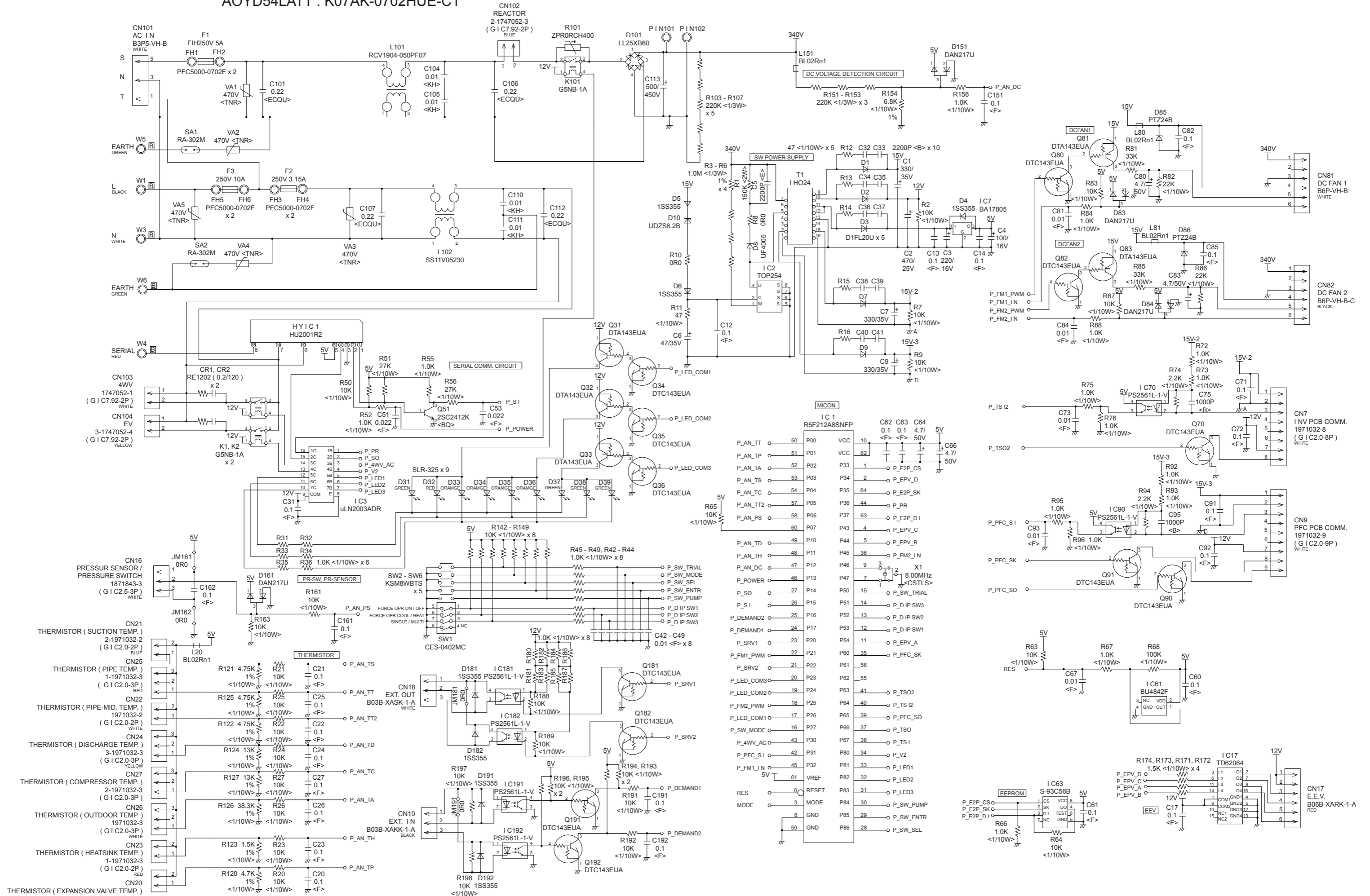

OUTDOOR UNIT POWER FACTOR PCB ASSEMBLY - 1

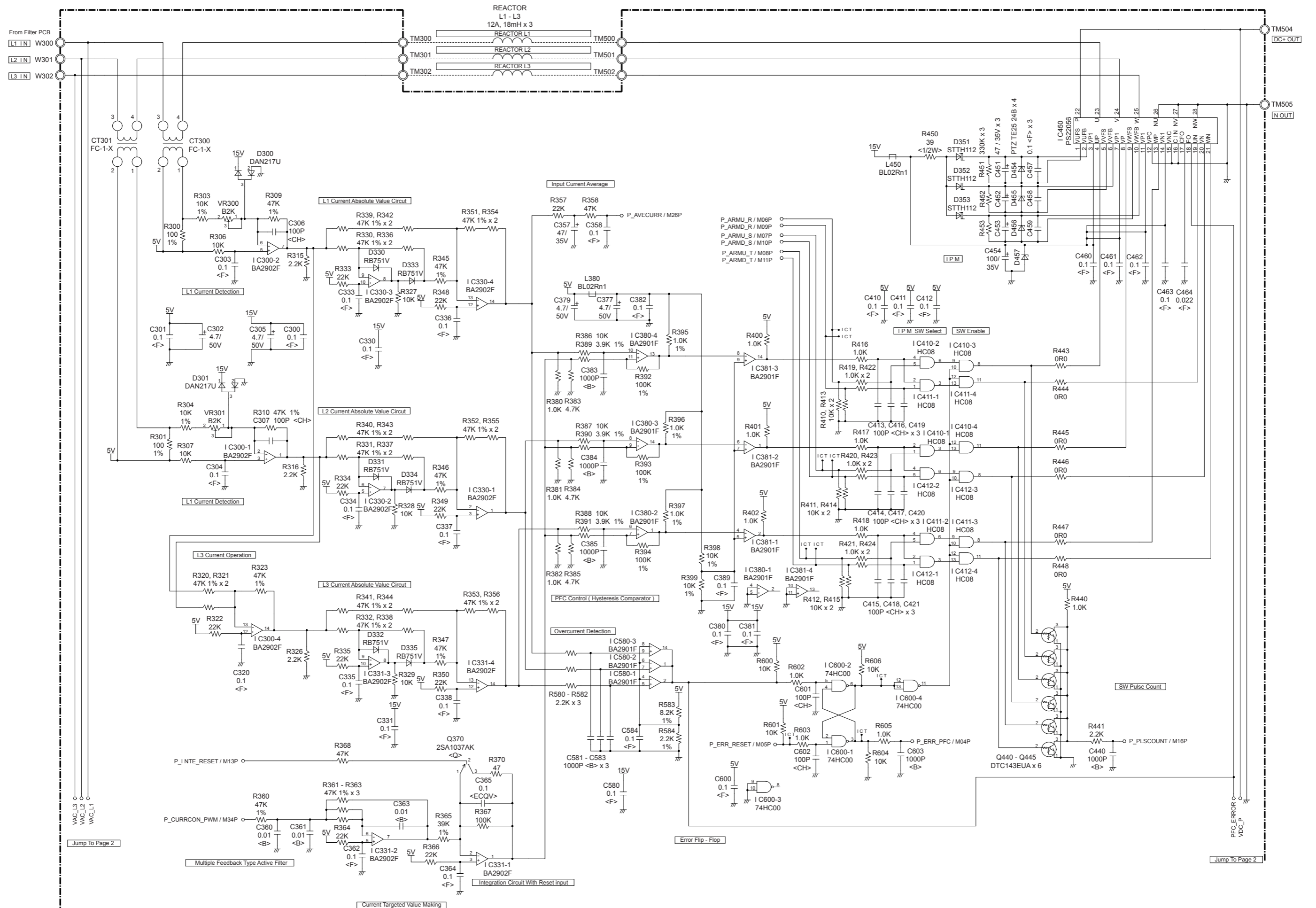

OUTDOOR UNIT POWER FACTOR PCB ASSEMBLY - 2

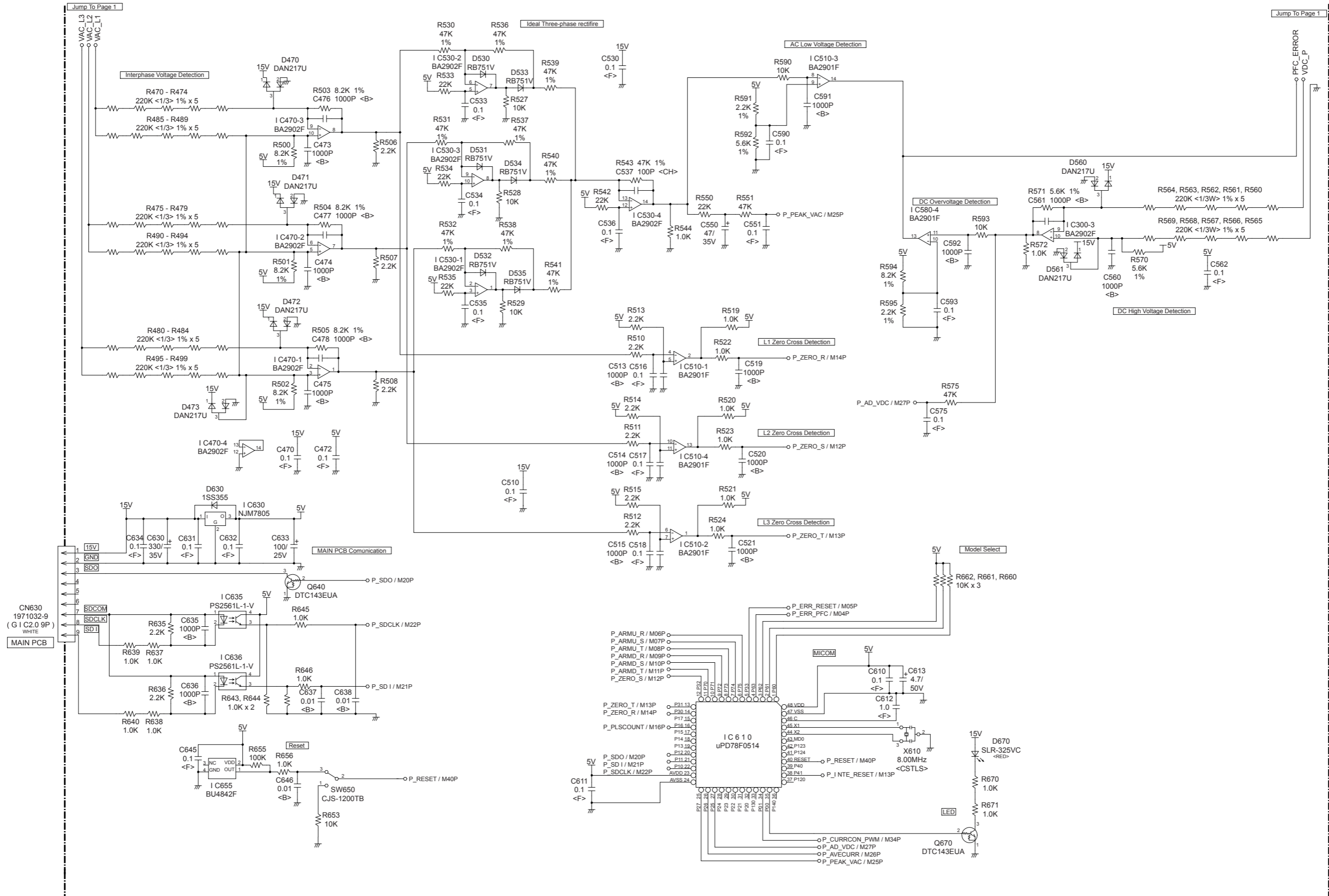

OUTDOOR UNIT
TRANSISTOR PCB ASSEMBLY (INVERTER)
K07AS-0700HUE-TR1

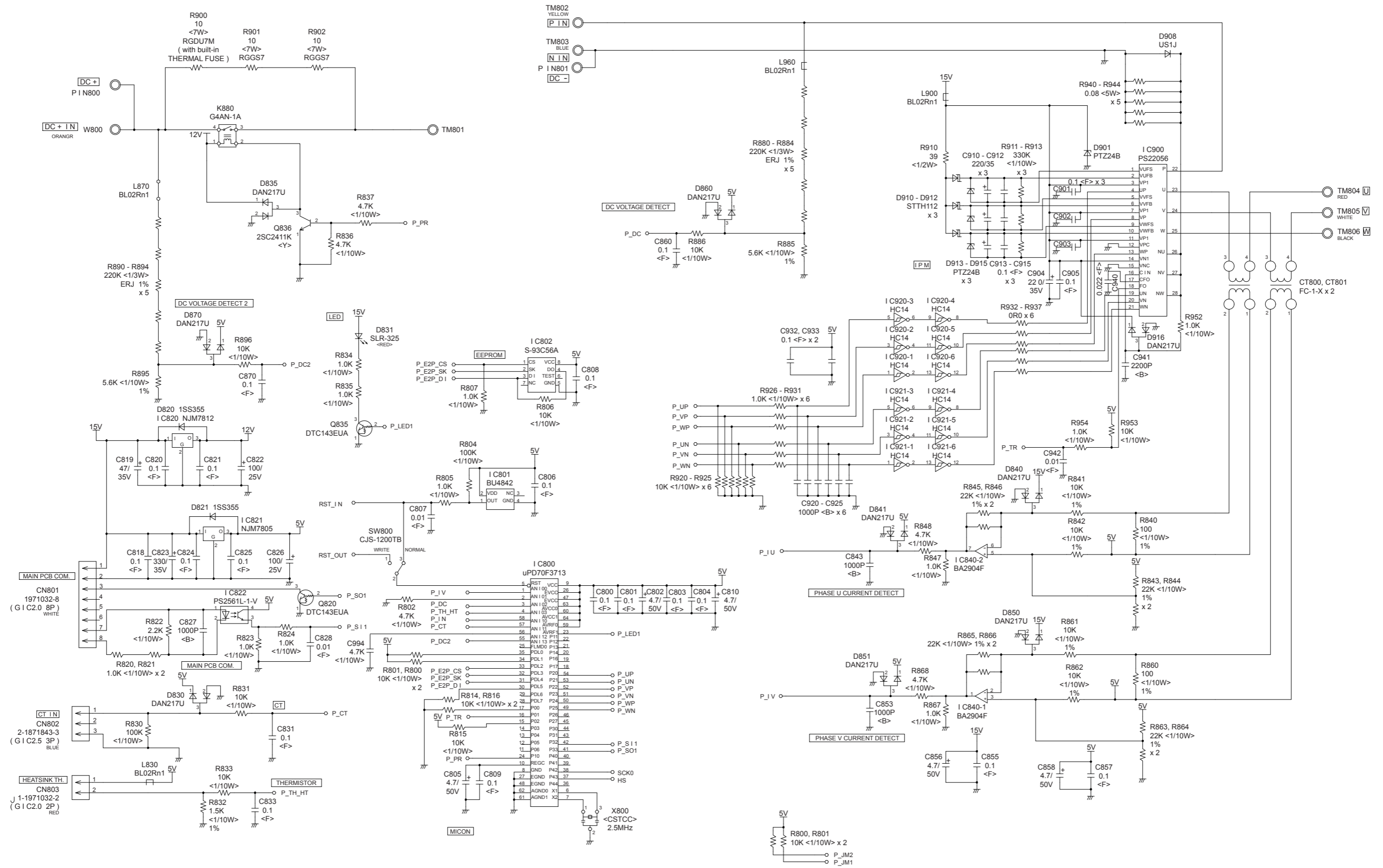

OUTDOOR UNIT POWER SUPPLY PCB ASSEMBLY K07AQ-0700HUE-FL0

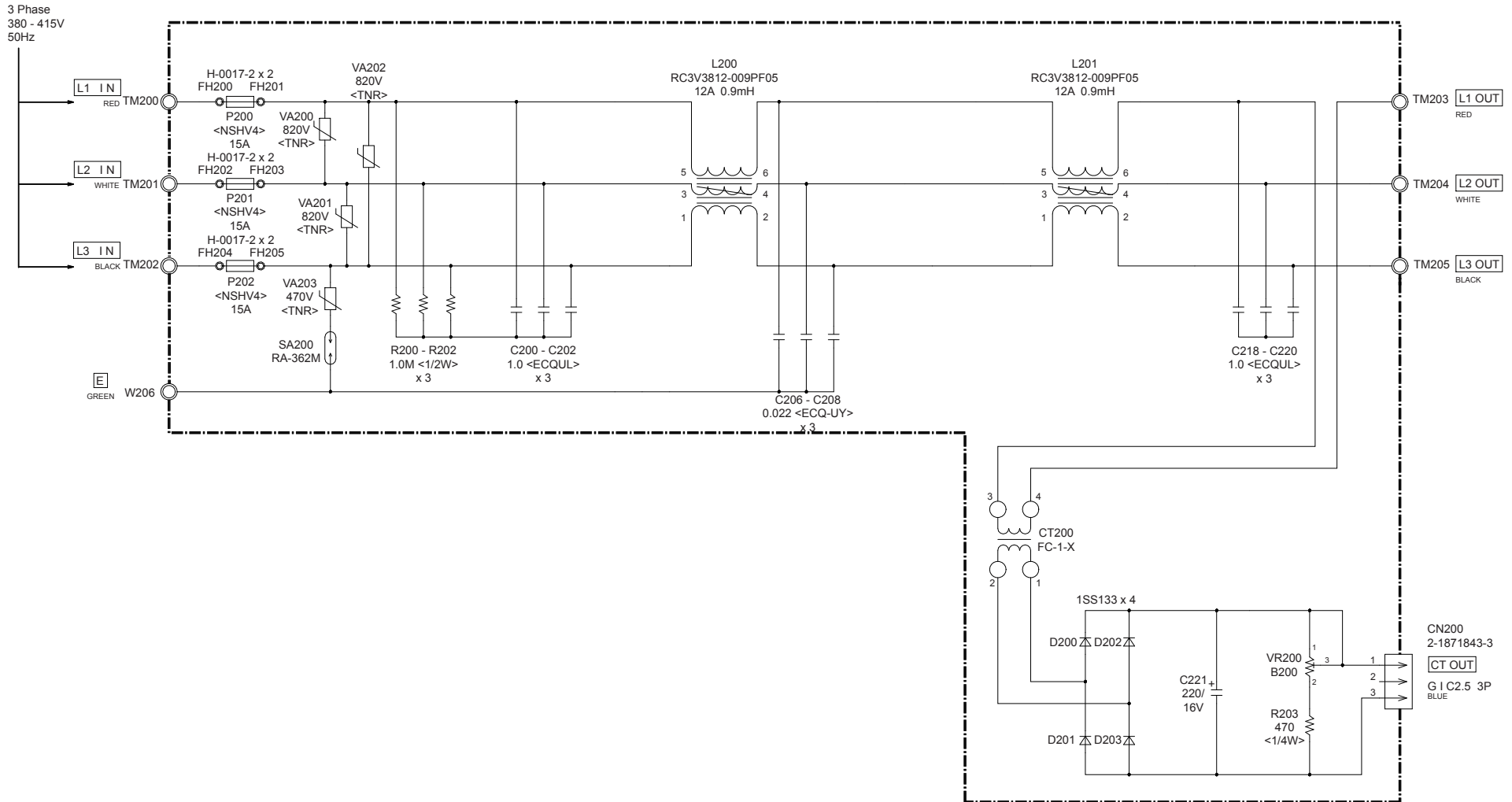

OUTDOOR UNIT
CAPACITOR PCB ASSEMBLY
K07AP-0700HUE-P0

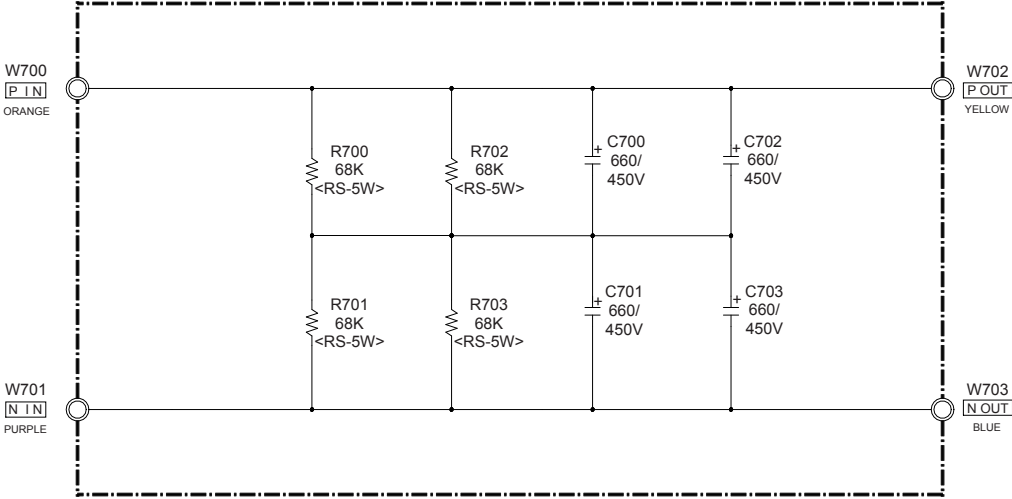

ERROR DETECTION

REMOTE CONTROL

Troubleshooting at the remote control LCD

This is possible only on the wired remote control.

Self-diagnosis

If an error occurs, the following display will be shown.
("EE" will appear in the set room temperature display.)

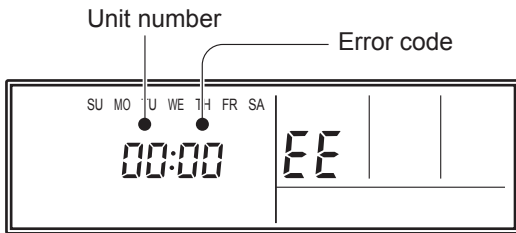

Ex. Self-diagnosis

If "CO" appears in the unit number display, there is a remote control error. Refer to the installation instruction sheet included with the remote control.

Error code	Error contents
01 13 26 27	Indoor signal error
00	Wired remote controller abnormal
02	Indoor room temperature sensor error
04	Indoor heat exchanger temperature sensor (middle) error
28	Indoor heat exchanger temperature sensor (inlet) error
09	Float switch operated
0c	Outdoor discharge pipe temperature sensor error
06	Outdoor heat exchanger temperature sensor (outlet) error
0A	Outdoor temperature sensor error
0E	Heat sink thermistor (Inverter) error
15	Compressor temperature sensor error
1d	2-way valve temperature sensor error
1E	3-way valve temperature sensor error
29	Outdoor heat exchanger temperature sensor (middle) error
2d	Heat sink thermistor (P.F.C.) error
20	Indoor manual auto switch abnormal
2A	Power supply frequency detection error
17	IPM protection
18	CT error
1A	Compressor location error
1b	Outdoor fan error
1F	Connected indoor unit abnormal
1c	Outdoor unit computer communication error
2E	Inverter error
12	Indoor fan abnormal
0F	Discharge temperature error
24	Excessive high pressure protection on cooling
2c	4-way valve abnormal
16	Pressure switch abnormal, Pressure sensor abnormal
2b	Compressor temperature error
2F	Low pressure error
19	Active filter abnormal
25	P.F.C. circuit error
30	Refrigerant circuit address set-up error
31	Master unit, Slave unit set-up error
32	Connected the indoor number set-up error
33	P.F.C. PCB error

OUTDOOR UNIT

TEST RUN

⚠ CAUTION

Always turn on the power 6 hours prior to the start of the operation in order to protect the compressor.

1. Check items before performing the test run

Make sure to perform the test run.

Before performing the test run, be sure to check the following points.

- (1) Is gas leaking?
Check connection of each pipe (flare connection part, brazing part).
- (2) Is a breaker installed to the power cable of the outdoor unit ?
- (3) Has each cable been securely connected to the terminal according to the specifications ?
- (4) Are the 3-way valves (gas pipes and liquid pipes) of the outdoor units open?
- (5) Has the power been supplied to the unit for at least 6 hours ?
- (6) Has the necessary local setting been done ?
- (7) Check insulation resistance of 1 MΩ or more using a 500V mega tester.

If no problems are found with the above items, perform the test run according to "Test run method".

If any problems are found, immediately resolve the problem and re-check the items.

2. Test run method

⚠ CAUTION

If the test run is performed for 1 outdoor unit in a group control system installation, the test run will also be performed for the other units. Therefore, make sure that all of the units have been installed before starting a test run.
(Group control system installation described in "SPECIAL INSTALLATION METHODS" in the installation manual of the indoor unit.)

Operate [ENTER] (TEST RUN) switch on the display board by the following procedure.

[Controller PCB Assy of control unit]

LED display part

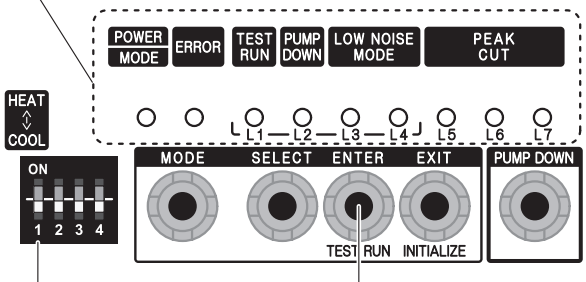

Operation mode
Upper : HEAT
Lower : COOL

[ENTER] (TEST RUN) switch

2.1. Operating procedures for the test run

- (1) Check the 3-way valves (both at the liquid side and gas side) are opened.
- (2) Set the operation mode to "COOL" or "HEAT".

POWER MODE	ERROR	TEST RUN (L1)	PUMP DOWN (L2)	LOW NOISE (L3) (L4)		PEAK CUT (L5) (L6) (L7)		
●	○	○	○	○	○	○	○	○

Sign "●" lights on.

In the first test run, be sure to set the operation mode to "COOL".

The operation mode cannot be switched between "COOL" and "HEAT" during the test run. To switch the operation mode between "COOL" and "HEAT", stop the test run, switch the operation mode, and then start the test run again.

- (3) Press [ENTER] (TEST RUN) switch for more than 3 seconds.

POWER MODE	ERROR	TEST RUN (L1)	PUMP DOWN (L2)	LOW NOISE (L3) (L4)		PEAK CUT (L5) (L6) (L7)		
●	○	●	○	○	○	○	○	○

"TEST RUN" LED will light on.

If the compressor is operating at starting the test run, the compressor will stop and, after a while, the test run will start.

Either of the above "LOW NOISE" or "PEAK CUT" will light on during the test run if local setting function is selected.

- (4) Confirm operating status.
- (5) Press [ENTER] (TEST RUN) switch again.

POWER MODE	ERROR	TEST RUN (L1)	PUMP DOWN (L2)	LOW NOISE (L3) (L4)		PEAK CUT (L5) (L6) (L7)		
●	○	○	○	○	○	○	○	○

"TEST RUN" LED lights off, and TEST RUN stops.

Test run will finish after about 60 minutes automatically. At the same time, "TEST RUN" LED will light off.

Test run may be stopped before operating for 60 minutes if an error occurs after a starting test run.

OUTDOOR UNIT

ERROR CODE DISPLAY

When an error occurs, “short-press” the [ENTER] switch once. The number of blinks of the LED indicates the type of error.

1 How to check error code

1.1. Display when an error occurs

POWER MODE	ERROR	TEST RUN (L1)	PUMP DOWN (L2)	LOW NOISE (L3) (L4)		PEAK CUT (L5) (L6) (L7)		
●	Blinks (Hi-speed)	○	○	○	○	○	○	○

(1) Check that the “ERROR” LED blinks, and then “short-press” the [ENTER] switch once.

1.2. Display while an error code is blinking

POWER MODE	ERROR	TEST RUN (L1)	PUMP DOWN (L2)	LOW NOISE (L3) (L4)		PEAK CUT (L5) (L6) (L7)		
Blinks (Twice)	Blinks	○	○	○	○	○	○	○

(2) The “POWER MODE” LED will blink twice and the “ERROR” LED will blink several times.

The number of blinks of the “ERROR” LED varies according to the type of error. For details, refer to the right table.

2 Error code check table

Number of blinks (LED)	Error type
1	Serial forward transfer error
2	Discharge thermistor error
3	Heat-exchange thermistor (outlet) error
4	External temperature thermistor error
5	Heat-exchange thermistor (intermediate) error
6	Discharge temperature protection (permanent stoppage)
7	Compressor thermistor error
8	Heatsink thermistor (inverter) error
9	Pressure switch (sensor) error
10	Compressor temperature protection (permanent stoppage)
11	Connection with indoor unit error
12	Current trip (permanent stoppage)
13	Detection of compressor position error (permanent stoppage)
14	Compressor start up error (permanent stoppage)
15	Fan motor (1) error (permanent stoppage)
16	Fan motor (2) error (permanent stoppage)
17	Heatsink thermistor (P.F.C.) error
18	Inverter error
19	P.F.C. error
20	Low pressure abnormal
21	Indoor unit abnormality condition

SPECIAL INSTALLATION SETTING

OUTDOOR UNIT

PUMP DOWN (Refrigerant collecting operation)

Perform the following procedures to collect the refrigerant when moving the indoor unit or outdoor unit

⚠ WARNING
Never touch electrical components such as the terminal blocks or reactor except the switch on the display board. It may cause a serious accident such as electric shock.
⚠ CAUTION
Perform the pump down operation before disconnecting any refrigerant pipe or electric cable.
Collect refrigerant from the service port or the 3-way valve if pump down cannot be performed.
In case of a group control system installation, do not turn the power off pump down is completed in all outdoor units. (Group control system installation described in "SPECIAL INSTALLATION METHODS" in the installation manual of the indoor unit.)

Operate [PUMP DOWN] switch on the display board in the manner described below.

LED display part

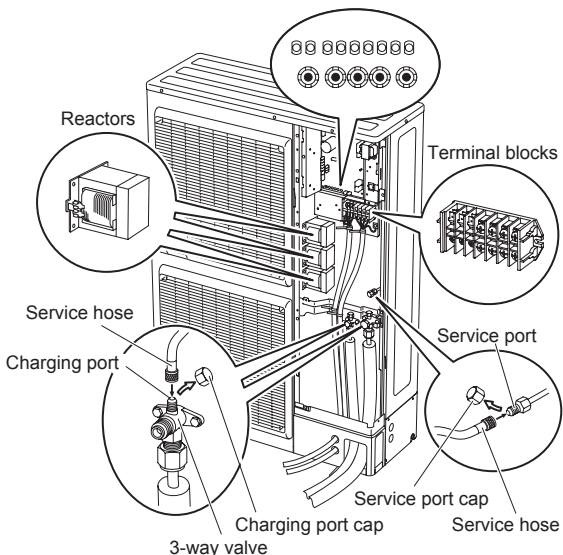
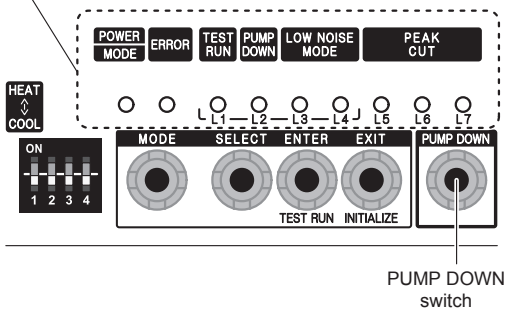

1. Preparation for pump down

Confirm that the power is off, and then open the service panel.

2. Pump down procedure

- (1) Check the 3-way valves (both at the liquid side and gas side) are opened.
- (2) Turn the power on.

POWER	ERROR	TEST RUN (L1)	PUMP DOWN (L2)	LOW NOISE (L3)	(L4)	PEAK CUT (L5) (L6) (L7)		
MODE								
●	○	○	○	○	○	○	○	○

- (3) Press [PUMP DOWN] switch for 3 seconds or more after 3 minutes after power on.

POWER	ERROR	TEST RUN (L1)	PUMP DOWN (L2)	LOW NOISE (L3)	(L4)	PEAK CUT (L5) (L6) (L7)		
MODE								
●	○	○	●	○	○	●	●	●

LED display lights on as shown in the above figure, and the fans and the compressor start operating.

If the [PUMP DOWN] switch is pressed while the compressor is operating, the compressor will stop, then start again in about 3 minutes.

- (4) LED display will change as shown below about 3 minutes after the compressor starts. Fully close the 3-way valve on the liquid pipe side at this stage.

POWER	ERROR	TEST RUN (L1)	PUMP DOWN (L2)	LOW NOISE (L3)	(L4)	PEAK CUT (L5) (L6) (L7)		
MODE								
●	○	○	●	○	○	○	●	●

If the valve on the liquid pipe side is not closed, the pump down cannot be performed.

- (5) When LED display changes as shown in the below figure, close the 3-way valve on the gas pipe side tightly.

POWER	ERROR	TEST RUN (L1)	PUMP DOWN (L2)	LOW NOISE (L3)	(L4)	PEAK CUT (L5) (L6) (L7)		
MODE								
●	○	○	●	○	○	○	○	●

If the valve on the gas pipe side is not closed, refrigerant may flow into the piping after the compressor stops

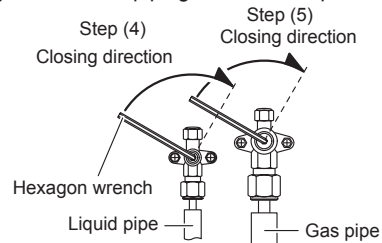

- (6) LED display changes after 1 minute as shown in the figure below

POWER	ERROR	TEST RUN (L1)	PUMP DOWN (L2)	LOW NOISE (L3)	(L4)	PEAK CUT (L5) (L6) (L7)		
MODE								
●	○	○	●	○	○	○	○	○

Fans and compressor stop automatically.

If the pump down is successfully completed (the above LED display is shown), the outdoor unit remains stopped until the power is turned off.

- (7) Turn the power off.

POWER	ERROR	TEST RUN (L1)	PUMP DOWN (L2)	LOW NOISE (L3)	(L4)	PEAK CUT (L5) (L6) (L7)		
MODE								
○	○	○	○	○	○	○	○	○

PUMP DOWN is completed.

(Note)

To stop pump down, press the [PUMP DOWN] switch again.

To start the pump down again after the compressor is automatically stopped due to an error, turn the power off and open the 3-way valves. Wait 3 minutes, turn the power on and start the pump down again.

When starting the operation after completion of the pump down, turn the power off, and then open the 3-way valves. Wait 3 minutes, turn the power on and perform a test run in the "COOL" operation mode.

PARTS

INDOOR UNIT

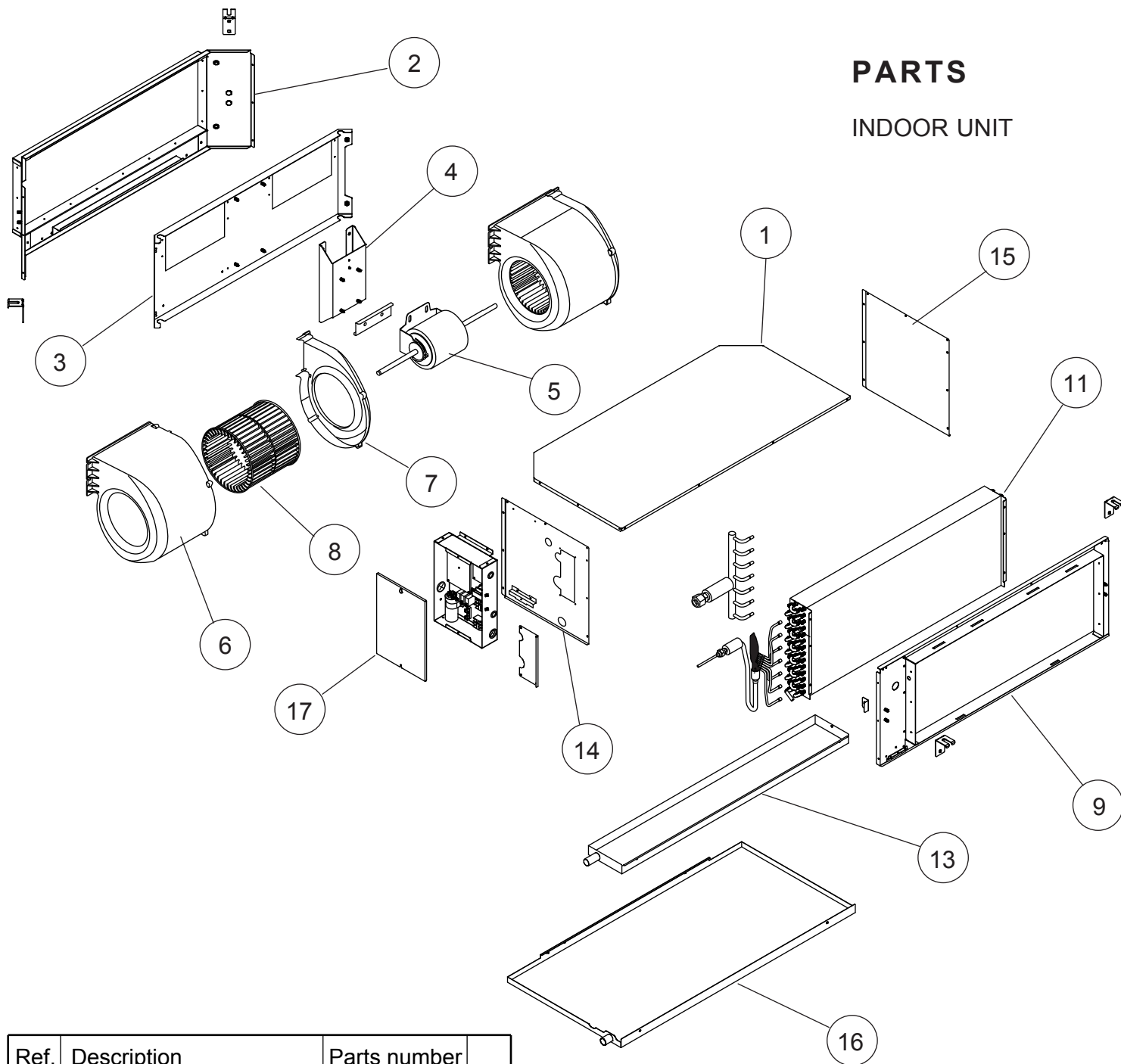

Ref.	Description	Parts number
1	Plate Top Sub Assy	9372576014
2	Kit (Panel Front Sub Assy)	9372637029
3	Panel Fan Assy	9372035009
4	Bracket Motor Assy	9372037003
5	Motor, Induct	9602802012
6	Casing A	9372057018
7	Casing B	9372058015
8	Sirocco Fan	9372059012
9	Kit (Panel Rear Sub Assy)	9372636022
10	Room Thermistor	9703299216
11	Evaporator Assy	9373875017
12	Pipe Thermistor	9703297113
13	Drain Pan Assy	9372579015
14	Kit (Panel Right Sub Assy)	9372916025
15	Kit (Panel Left Sub Assy)	9372581018
16	Drain Pan Sub Assy	9372582015
17	Cover Box	9372061008

(Connector : white) (Connector : black)

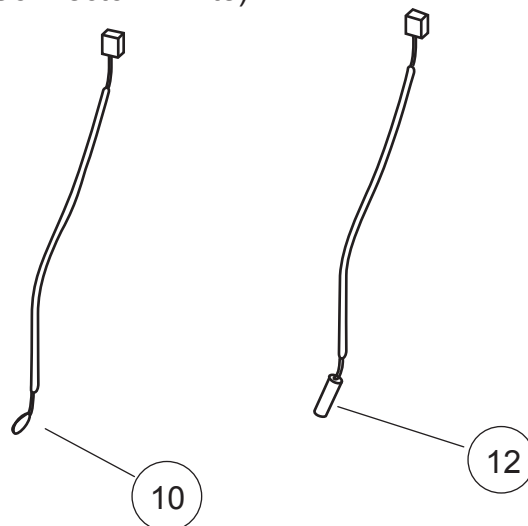

INDOOR UNIT

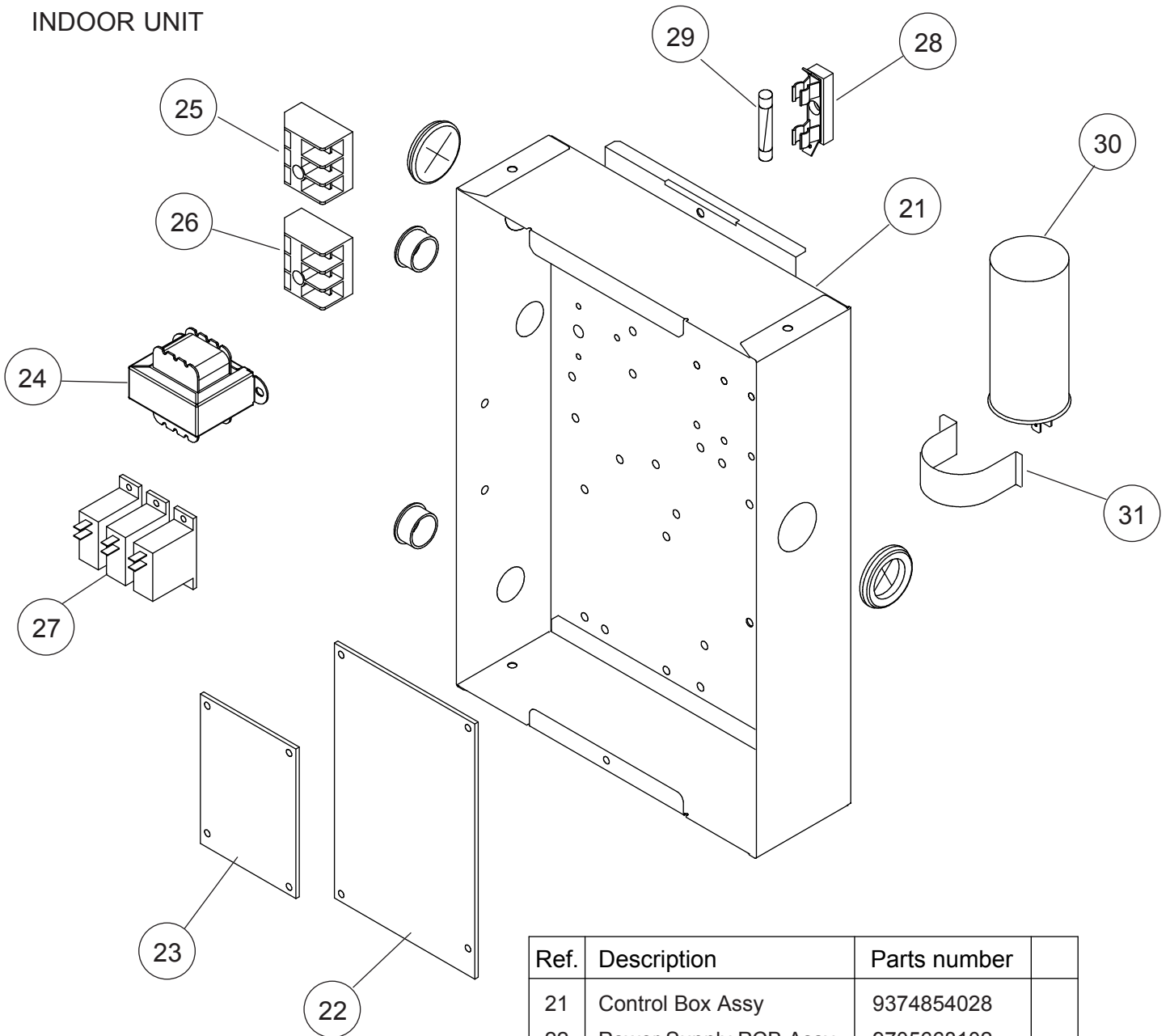

Ref.	Description	Parts number	
21	Control Box Assy	9374854028	
22	Power Supply PCB Assy	9705668102	
23	Controller PCB Assy (45) (K03BZ-0802HSE-C1)	9705246232	
23	Controller PCB Assy (54) (K03BZ-0801HSE-C1)	9705246225	
24	Transformer (Power)	9704129017	
25	Terminal 3P	9703345012	
26	Terminal 3P	9306489045	
27	Relay	9900294014	
28	Fuse Holder	0501454012	
29	Fuse	0600384029	
30	Capacitor, Plastic	9900269111	
31	Capacitor Clamp	9308114006	
--	Thermo. Spring A	313728262708	
--	Remote Control	9372266199	

PARTS

OUTDOOR UNIT

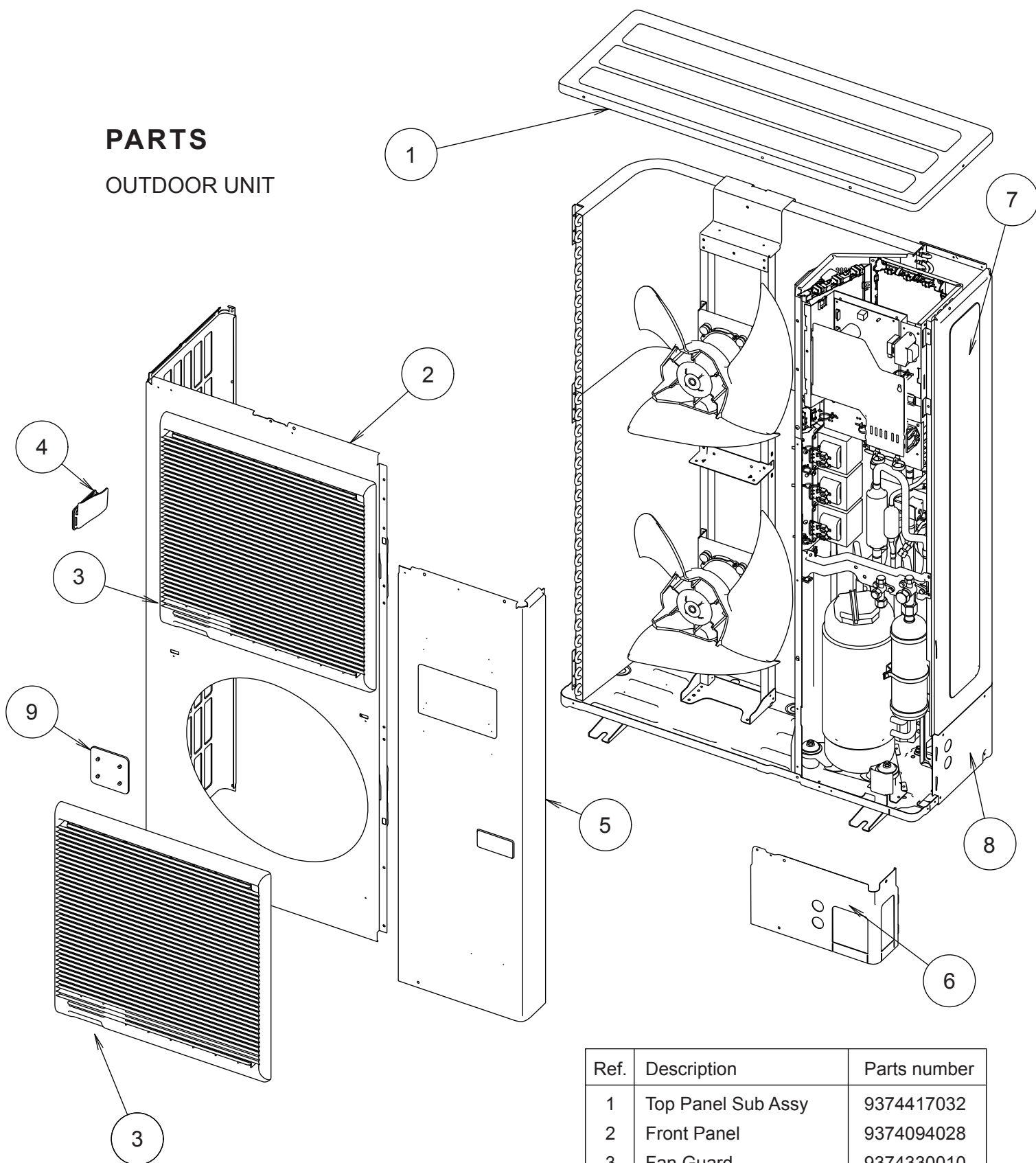

Ref.	Description	Parts number
1	Top Panel Sub Assy	9374417032
2	Front Panel	9374094028
3	Fan Guard	9374330010
4	Grip Side	9374173013
5	Sevice Panel Sub Assy	9374415076
6	Pipe Cover Front	9378861015
7	Right Panel Sub Assy	9374416158
8	Pipe Cover Rear	9378862012
9	Fan Guard Cover	9378111011
--	Emblem Rear	9351355005
--	Protective Net	9375381042

OUTDOOR UNIT

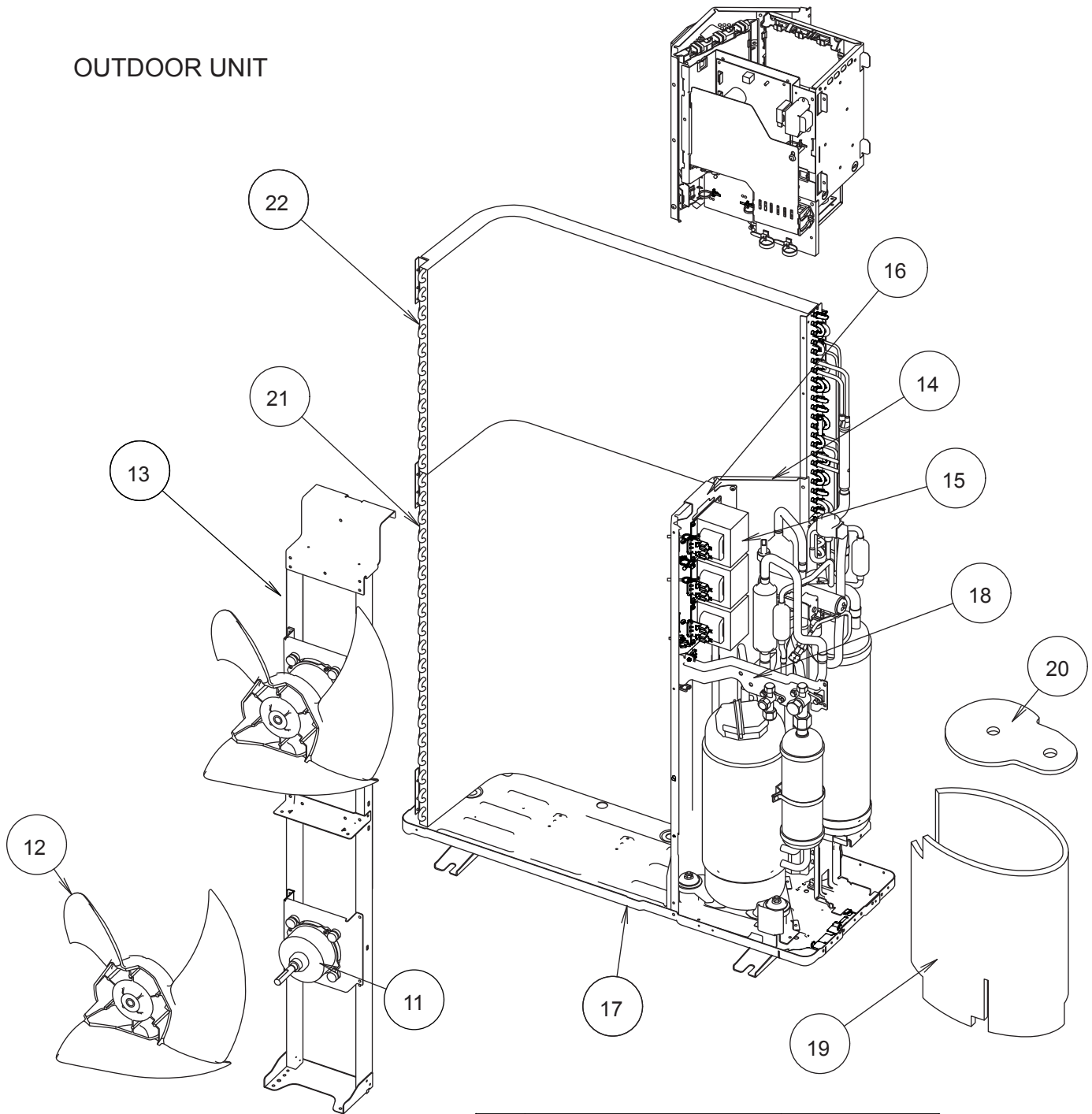

Ref.	Description	Parts number
11	Motor DC Brushless	9602749010
12	Propeller Fan Assy	9366378020
13	Motor Bracket Sub Assy	9374418145
14	Separate Wall Sub Assy	9374413195
15	Reactor Assy	9900246013
16	Reactor Holder Sub Assy	9379067003
17	Base Assy	9374166220
18	Valve Plate	9378804012
19	Compressor Cover A	9378611023
20	Compressor Cover B	9378612020
21	Condenser A Assy	9374433018
22	Condenser B Assy	9374434015

OUTDOOR UNIT

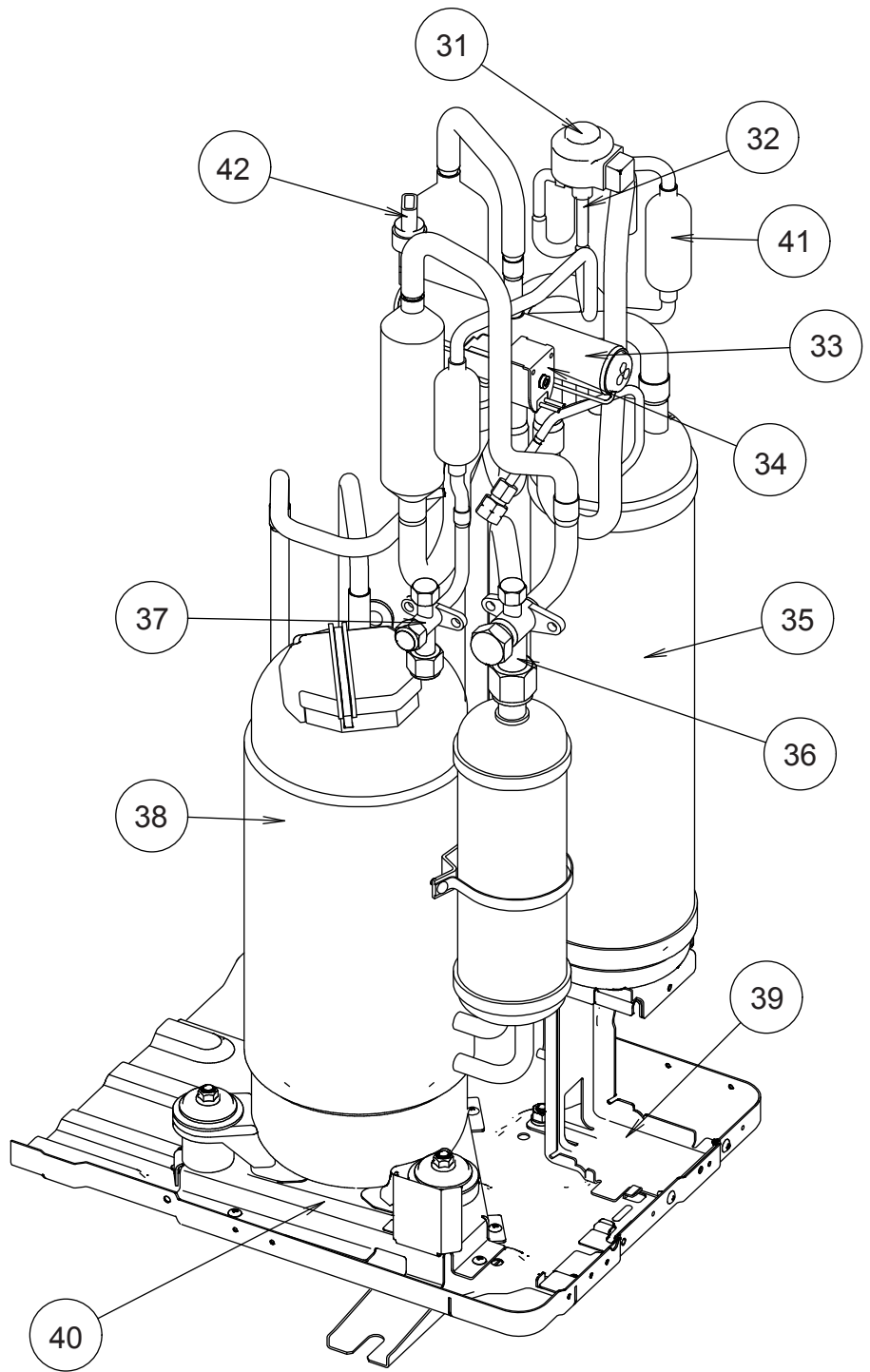
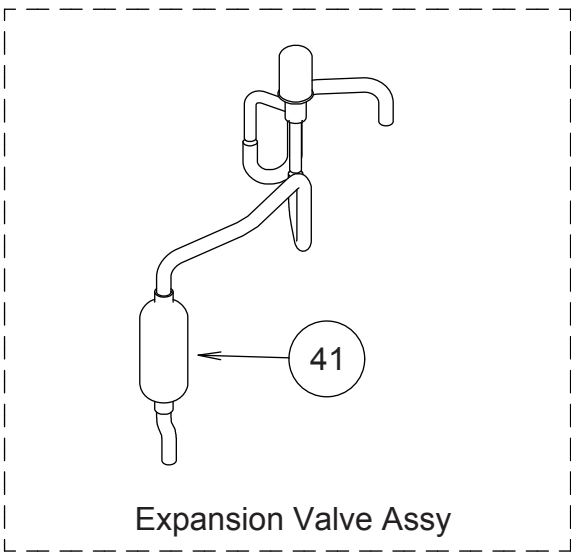
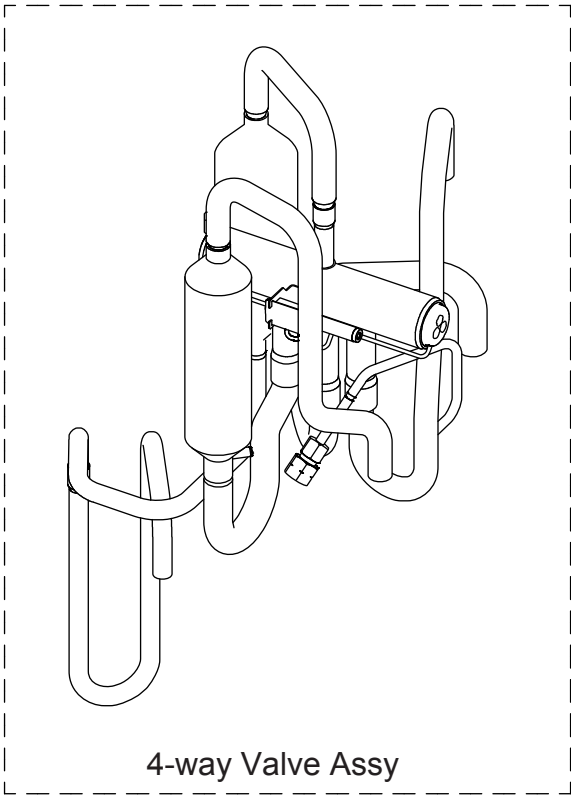

Ref.	Description	Parts number
31	Coil (Expansion Valve)	9900190057
32	Expansion Valve Assy	9370947182
33	4-way Valve Assy	9374425167
34	Solenoid	9970055041
35	Accumulator	9379014014
36	3-way Valve Assy	9379079006
37	3-way Valve Assy	9379077002
38	Compressor Assy	9379013017
39	Accumulator Holder	9378800014
40	Comp Plate Assy	9378826014
41	Strainer Assy	9372524039
42	Sensor	9900505011



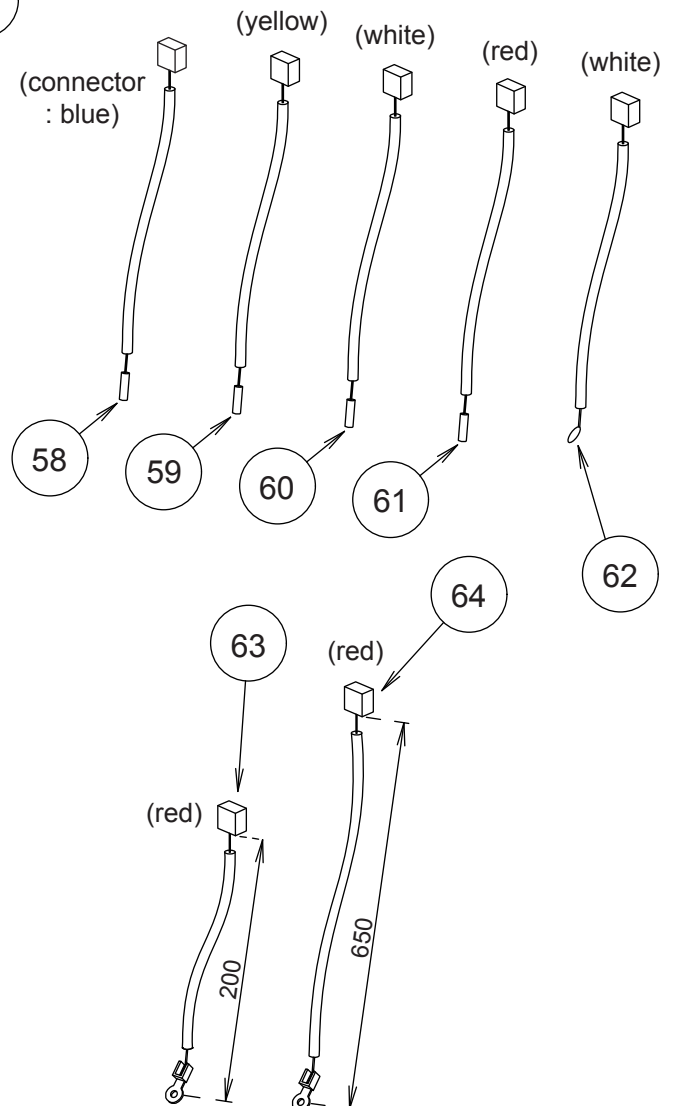
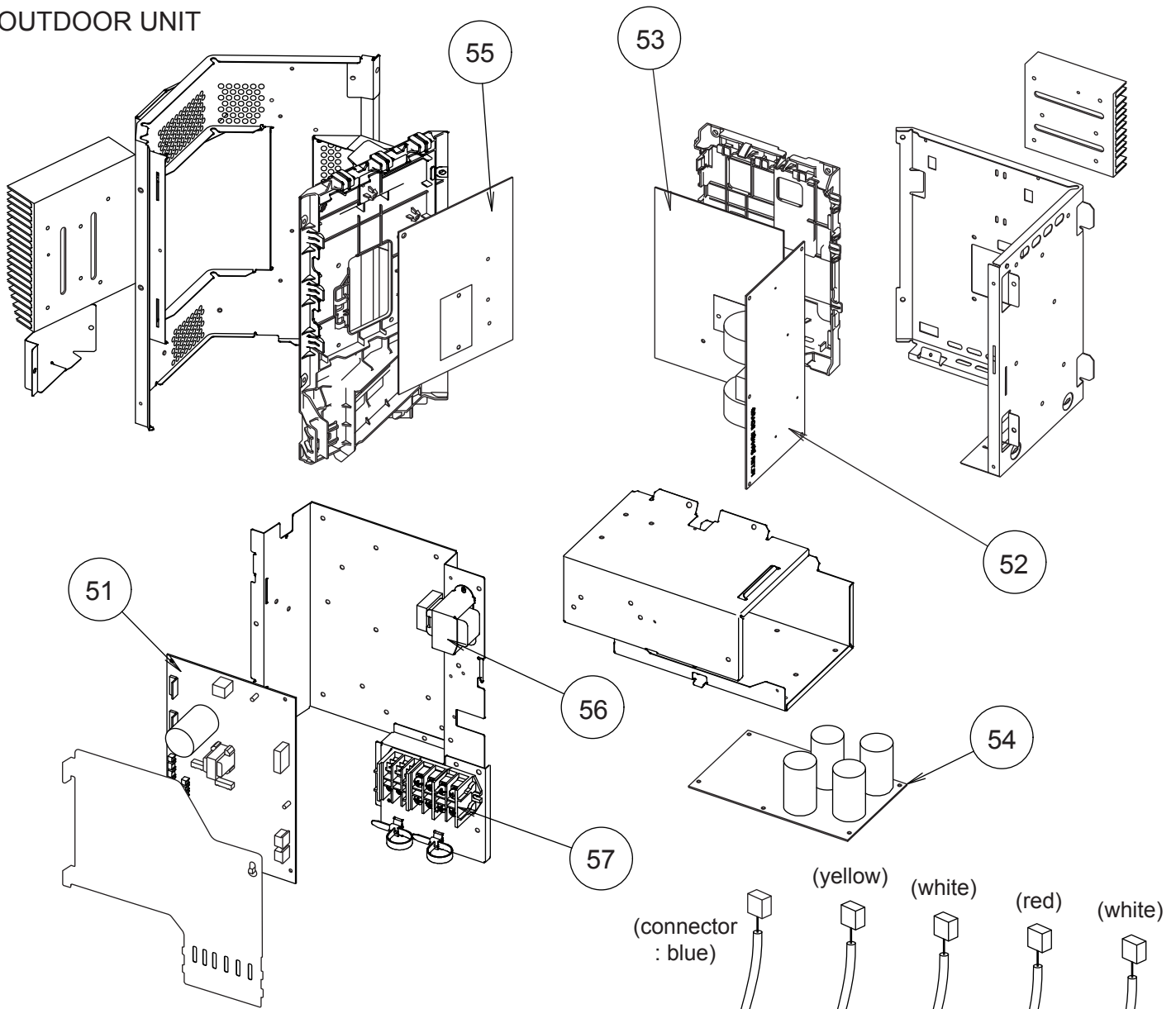



OUTDOOR UNIT



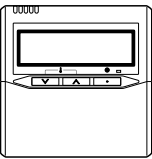
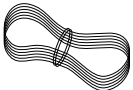

Ref.	Description	Parts number
51	Main PCB Assy (45)	9707627022
51	Main PCB Assy (54)	9707627039
52	Filter PCB Assy	9707609011
53	PFC PCB Assy	9707629019
54	Capacitor PCB Assy	9707608014
55	Inverter PCB Assy	9707628012
56	Reactor Assy	9900481018
57	Terminal	9900428082
58	Compressor Thermistor	9900516000
59	Thermistor (Discharge)	9900515003
60	Thermistor (Heat Exchanger Med)	9900513009
61	Thermistor (Heat Exchanger Out)	9900514006
62	Thermistor (Outdoor)	9900517007
63	Heatsink Thermistor (Inverter)	9900518011
64	Heatsink Thermistor (PFC)	9900518028

ACCESSORIES

INDOOR UNIT

Name and Shape	Q'ty	Application	Part number
Special nut A (large flange) 	4	For suspending the indoor unit from ceiling	313005446653
Special nut B (small flange) 	4		313005446759
Coupler heat insulation (large) 	1	For indoor side pipe joint (large pipe)	9378173569
Coupler heat insulation (small) 	1	For indoor side pipe joint (small pipe)	9378173521
Binder 	1	Fixing the remote cord	313361275805
Remote control 	1	For air conditioner operation	9372266199
Remote control cord 	1	For connecting the remote control	9372714010
Tapping screw (ø4 × 16) 	2	For installing the remote control	0700181108

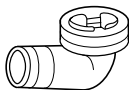
OUTDOOR UNIT

Name and Shape	Q'ty	Application	Part number
Drain pipe 	1	For drain piping work	9303029015
Drain cap 	2		313166024302

0811G3564